



Proteus

Waterproofing



PRO-LIVING[®] GREEN ROOFS





PRO-LIVING®

COULD THIS BE THE
GREENEST GREEN ROOF
SYSTEM EVER?

Pro-Living® from Proteus Waterproofing could be the greenest green roof system ever launched in the UK.

When specifying or installing a Pro-Living® roof using Proteus' unique Cold Melt® membrane, you are combining environment friendly materials such as recycled rubber crumb and organically grown products with all that nature can offer.

Cold Melt® is certified by the BBA to last for the life of the building on which it is installed so you get the best of both worlds – strength and sustainability in one system.



WE NEVER FORGET YOU HAVE A CHOICE

At Proteus we never forget that you have a choice which is why our green and blue roof systems work with a wide range of other membranes that we supply to ensure that our green and blue roofs – intensive or extensive - can meet almost any budget or design specification.

Choose your membrane

- **Proteus Pro-Felt® – Built up felt system**
- **Proteus Hot Melt®**
- **Proteus Liquid Systems**
- **Cold Melt®**

Choose the right materials

Protecting the building's construction and flat roof waterproofing is vital. When burying Proteus' high performance roof systems, longevity is enhanced by protecting it from the effects of UV. Some systems such as Cold Melt® will outlast the life of the building structure they're installed upon.

Choosing a Pro-Living® green or bio-diverse system from Proteus can provide ecological benefits and more; energy efficiency is enhanced too. Studies show a building's internal air temperature remains more constant; hotter in winter and cooler in summer meaning air conditioning and heating systems are relied upon less.

Pro-Living® can help you to create a rooftop garden or communal space, a pleasant environment to spend time in. Terraces can offer additional living space when created using a Proteus paving system. Walkways can meander through bio-diversity.

If functionality is a priority then a Pro-Living® Blue Roof is the solution. Our range can be adapted to the building's needs, attenuating water, absorbing and holding the initial downpour then releasing it from the roof as designed. This can significantly reduce the impact of localised flooding or the need for underground tanks or further adaptations to drainage systems.

A bio-diverse Pro-Living® Roof gives colour to the rooftop as different species of plants are introduced. Wildflower meadows can be created or a more uniform planting regime utilising flowers and shrubs, offering homes for invertebrates within the berms and mounds.

PRO-LIVING® PRODUCTS

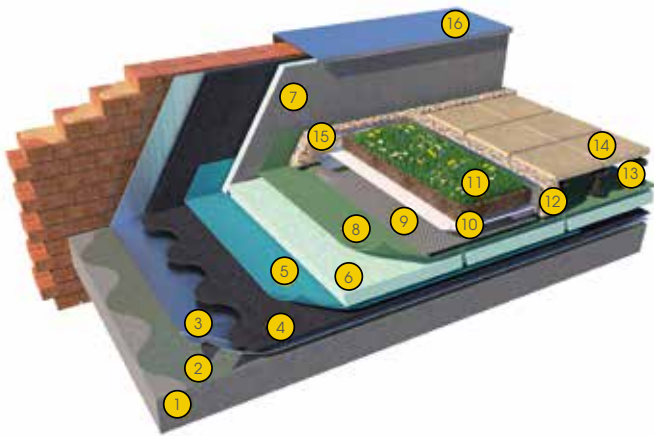

COLD MELT®

- 1 Deck
- 2 Pro-Prime® SA
- 3 Pro-Carrier SA
- 4 Cold Melt®
- 5 Proteus Anti-Root Membrane
- 6 Proteus Pro-Therm XPS
- 7 Proteus Cement Topped XPS
- 8 Proteus Low-K Water Reducing Layer
- 9 Proteus Pro-Living® Drainage Layer
- 10 Proteus Pro-Living® Filter Fleece
- 11 Proteus Pro-Living® Pre-Cultivated Green Roof Covering
- 12 Washed Rounded Ballast
- 13 Proteus Pedestal
- 14 Hard Landscaping / Paving
- 15 Proteus Pro-Living® Drainage Trim
- 16 Metal Capping

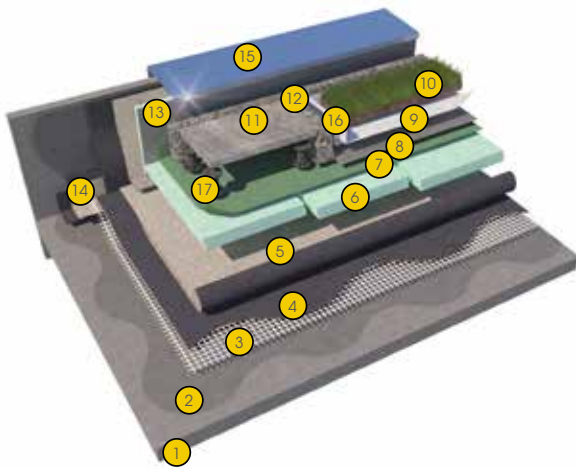

PROTEUS HOT MELT®

- 1 Deck
- 2 Pro-Prime® Bitumen
- 3 Proteus Hot Melt® Force
- 4 Proteus Hot Melt® Compound
- 5 Proteus Hot Melt® Sanded Capsheet / Proteus Anti-Root Capsheet
- 6 Proteus Pro-Therm XPS
- 7 Proteus Low-K Water Reducing Layer
- 8 Proteus Pro-Living® Drainage Layer
- 9 Proteus Pro-Living® Filter Fleece
- 10 Proteus Pro-Living® Green Roof Covering
- 11 Hard Landscaping / Paving
- 12 Washed Rounded Ballast
- 13 Proteus Cement Topped XPS
- 14 Proteus Hot Melt® Soaker Detail
- 15 Metal Capping
- 16 Proteus Pro-Living® Drainage Trim
- 17 Proteus Pedestal

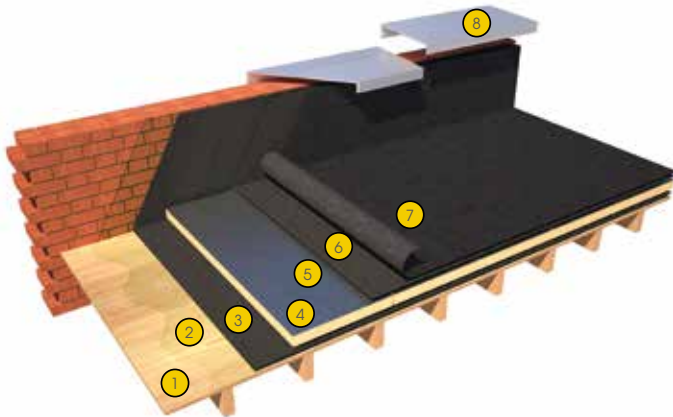

PROTEUS PRO-FELT®

- 1 Deck
- 2 Pro-Prime® Bitumen
- 3 Proteus Pro-Felt® SA Underlay Film VCL
- 4 Proteus Pro-Therm PIR
- 5 Pro-Prime® SA
- 6 Proteus Pro-Felt® SA Underlay Plain
- 7 Proteus Pro-Felt® Anti-Root Capsheet
- 8 Metal Capping

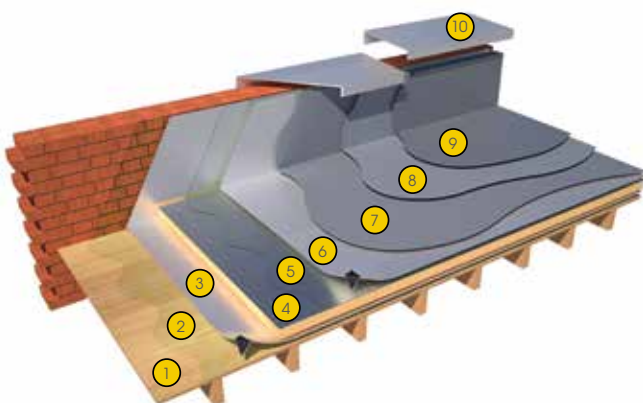

PROTEUS PRO-SYSTEM®

- 1 Deck
- 2 Pro-Prime® SA
- 3 Pro-Vapour SA
- 4 Proteus Pro-Therm PIR
- 5 Pro-Prime® SA
- 6 Pro-Carrier SA
- 7 Proteus Pro-System® 25 Base Coat
- 8 Proteus Pro-System® 25 Intermediate Coat
- 9 Proteus Pro-System® 25 Top Coat
- 10 Metal Capping

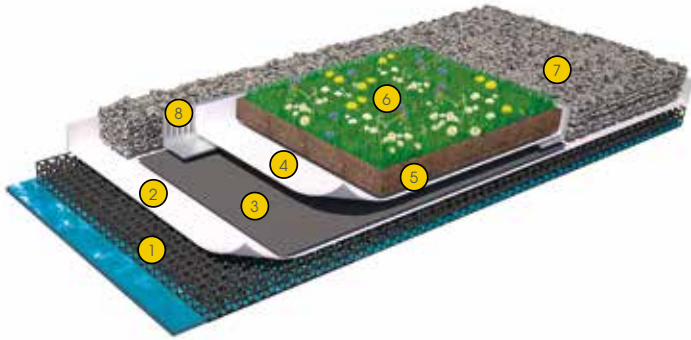

PRO-LIVING® BLUE ROOFS

- 1 Proteus Pro-Living® Reservoir/Water Attenuation Layer
- 2 Proteus Pro-Living® Filter Fleece
- 3 Proteus Pro Living® Drainage/Reservoir Board
- 4 Proteus Pro-Living® Filter Fleece
- 5 Proteus Pro-Living® Substrate
- 6 Proteus Pro-Living® Pre-Cultivated Green Roof Covering
- 7 Washed Rounded Ballast
- 8 Proteus Pro-Living® Drainage Trim

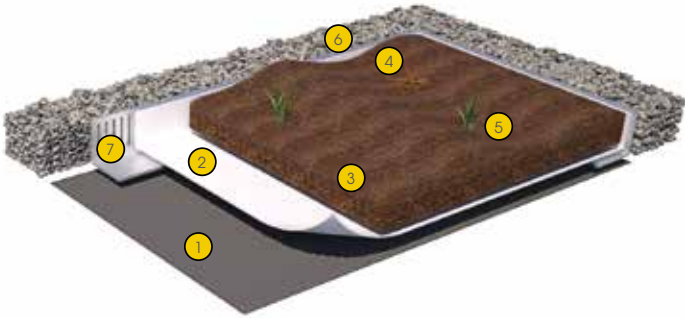

PRO-LIVING® BIODIVERSE ROOFS

- 1 Proteus Pro-Living® Drainage/Reservoir Board
- 2 Proteus Pro-Living® Filter Fleece
- 3 Proteus Pro-Living® Substrate (Engineered Soil)
- 4 Proteus Pro-Living® Log piles
- 5 Proteus Pro-Living® Plug plants
- 6 Washed Rounded Ballast
- 7 Proteus Pro-Living® Drainage Trim

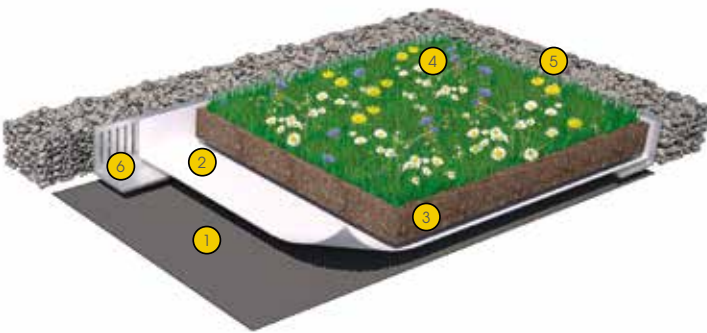

PRO-LIVING® GREEN ROOFS

- 1 Proteus Pro Living® Drainage/Reservoir Board
- 2 Proteus Pro-Living® Filter Fleece
- 3 Proteus Pro-Living® Substrate
- 4 Proteus Pro-Living® Pre-Cultivated Green Roof Covering
- 5 Washed Rounded Ballast
- 6 Proteus Pro-Living® Drainage Trim

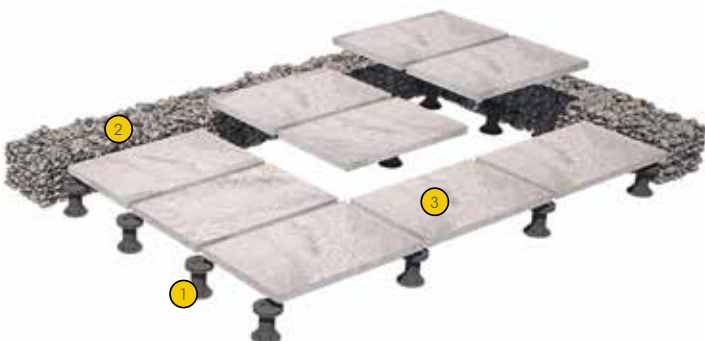

PAVING SYSTEMS

- 1 Adjustable paving supports
- 2 Washed rounded ballast
- 3 Hard landscaping/paving

The benefits of green roofs include:

- *Reducing problems of water run-off and better storm water management*
- *Building insulation*
- *Enhanced aesthetics*
- *Providing habitats for birds and insects*
- *Contributing to improvement of urban air quality*
- *Cooling the urban environment*
- *Contributing to reduced noise pollution*
- *Aesthetically improves the look of flat roof areas*
- *Improves sound absorption by as much as 8db compared with traditional flat roof systems*



What type of roof?

Green roofs can be intensive, with gardens on rooftops, with shrubs, climbers, perennials, bedding and even small trees. Alternatively they can be extensive, with green carpets of low maintenance creeping plants.

Extensive green roofs

These generally require an 8-15cm (3-6in) depth of growing medium that can consist mainly of lightweight inorganic materials such as perlite, leca, sand, rockwool and crushed tiles or concrete.

FLL Guidelines (2008) and the GRO Code (2014) are of paramount importance when constructing any living roof. A Pro-Living® Roof will support your choices to achieve compliance. The typical layers of an extensive green roof include waterproofing and insulation layers, a root barrier membrane, a drainage/reservoir layer, a filter layer and then the growing medium above.

It may be necessary to incorporate drains into the system, which should be boxed in to prevent them clogging up.





Intensive green roofs

These are usually container or raised bed gardens. They need at least 30cm (1ft) depth of growing medium, much of which needs to be organic matter. Proteus will advise you as to the best way forward with this type of installation.

Why choose a Proteus Green Roof?

Proteus offers some of the world's most technically advanced waterproof membranes along with considerable in-house expertise to advise on and support every green and blue roof installation.

Our products are tested to the highest standards and where possible, we select the most environmentally friendly materials that will promote bio-diversity and optimise ecological and economical excellence. That's why you should choose us.

Proteus Waterproofing – Experts in Green and Blue Roofing!



Manufactured in the UK and Europe, Proteus Waterproofing is one of the most innovative, fast growing companies in the waterproofing market. Proteus Waterproofing is a single source systems supplier, with an array of hot and cold-applied waterproofing and protection systems. The company's comprehensive product range is suitable for high performance roofing, balconies, walkways and car parks. It offers a vast range of systems, that have been engineered to meet the harshest of weather conditions and provide a lasting and robust waterproofing solution, in both refurbishments and new builds.

Experts in all forms of liquid applied and bituminous membrane roofing and waterproofing. Proteus Waterproofing is adaptable to each client's individual needs and circumstances, and offers long-term performance product reliability and a simple installation as standard.

Total Peace of Mind

Proteus Waterproofing roofing systems are tested to the most rigorous international standards, ensuring they will outperform the initial design life. This will give your project a durable, reliable and long-lasting waterproofing finish, that will last for many years to come, providing excellent value to clients and building owners.

Guaranteed Performance

Proteus Waterproofing presents clients with a robust choice of guarantees for its bespoke systems, from an offer that also incorporates enhanced independently-backed warranties, for total peace of mind.

For further information, please contact Proteus Waterproofing to discuss the most suitable option to meet your requirements.

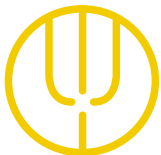

Proteus Industrial Technologies Ltd.
21a Sirdar Road, Brook Road Industrial Estate, Rayleigh, Essex SS6 7XF
T: +44 (0) 1268 777871

enquiries@proteuswaterproofing.co.uk
www.proteuswaterproofing.co.uk

 @Proteus_UK

Registered Office: 21a Sirdar Road, Brook Road Industrial Estate, Rayleigh, Essex. SS6 7XF.
Registered company number: 08258719.

Proteus Waterproofing's range of lasting and robust systems includes:

- *Liquid-applied waterproofing: Proteus Pro-System® Plus*
- *Inverted roof waterproofing: Cold Melt®, Proteus Hot Melt®*
- *High performance felts: Proteus Pro-Felt®, Ultima, Ultima Plus, Extra, Extra Plus*
- *Balconies and walkways: Pro-BW® Plus, Cold Melt®*
- *Car park decking systems: Deckmaster*
- *Coating protection: Pro-Cryl®, Pro-Solar Reflect*
- *Exterior walls waterproofing: Monosil, Monodex & Monodex Textured*

The Proteus Waterproofing Specification includes:

- *On-going technical support*
- *Comprehensive guarantees*
- *Free roof evaluations service*
- *Roof condition surveys, reports and bespoke specifications*
- *Expert advice on low maintenance solutions*
- *Site survey and design stage involvement*
- *Thermal value calculations to building regulations part 'L'*
- *Tapered insulation scheme design*
- *Wind uplift calculation*
- *Building regulations Part B (fire) compliance options*

The Proteus Waterproofing service package includes:

- *Detailed specifications*
- *National contractor base*
- *Technical manager inspections throughout the project*
- *Installation sign off*

